

HD/EX MOUNT KIT 16061030 FORD F-650/F-750, 2016+

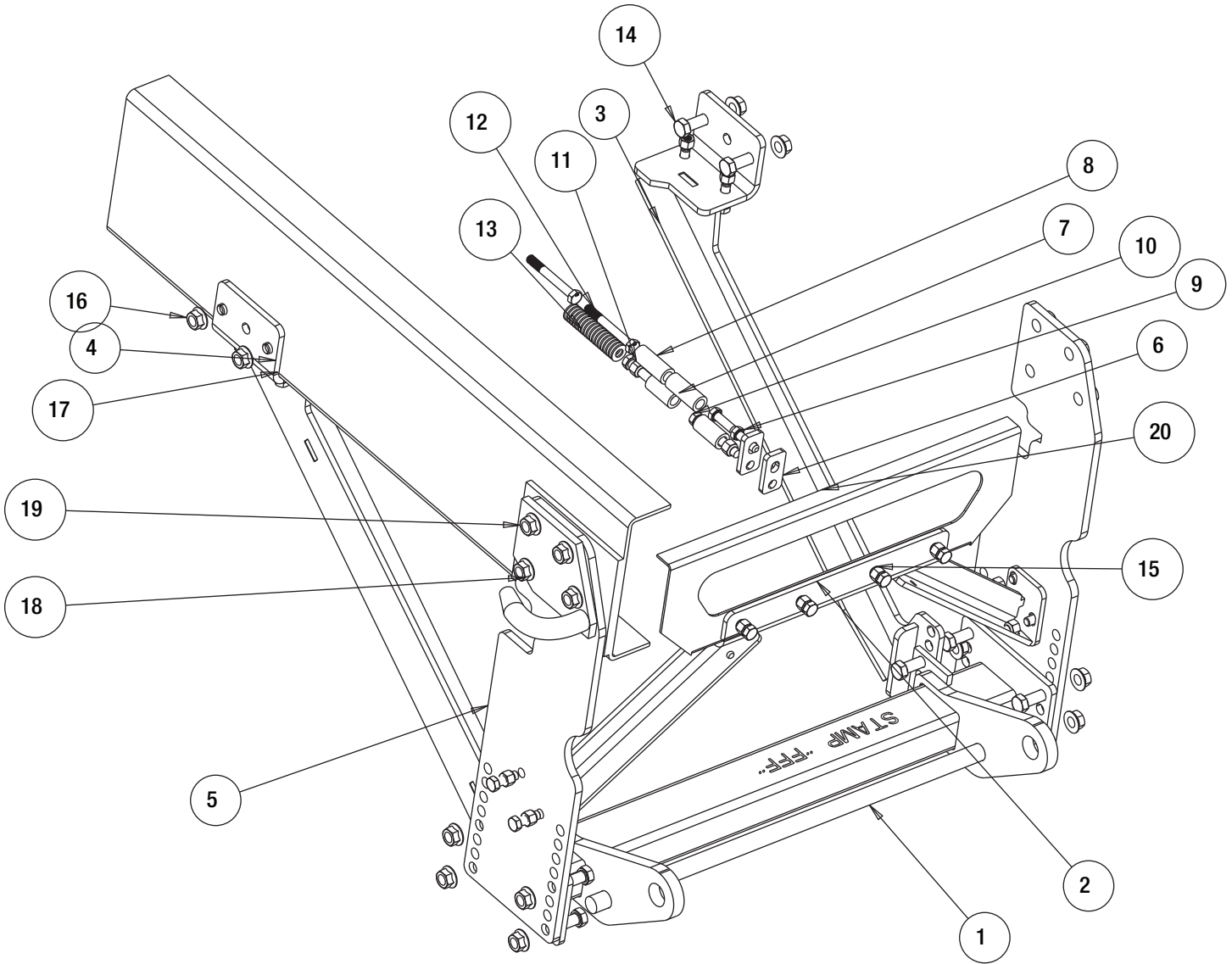

SnowDogg™ Snowplow

TRUCK MOUNT INSTALLATION MANUAL



Parts List

ITEM	PART NO.	QTY.	DESCRIPTION
1	16061031	1	PUSHBAR, F650 CM
2	16061032	1	MID BRACE, SPACING, F650
3	16061033	1	REAR BRACE,DS, LONG F650, 17
4	16061034	1	REAR BRACE,PS, LONG F650, 17
5	3034465	2	SIDEPLATE, UNI-MUNI MOUNT
6	3034475	2	SPACER TAB, SLOT
7	3034477	2	TUBE, SPACER BOTTOM, BUMPER
8	3034476	2	TUBE, SPACER TOP, BUMPER
9	3009978	2	SCREW M12-1.75x 40 MM HH CLASS 10.9 ZN

ITEM	PART NO.	QTY.	DESCRIPTION
10	FCS050013350YZ	2	SCREW, HEX HEAD CAP 1/2-13 X 3.50 GR 5 YZ
11	3002397	14	LOCKNUT, HEX NYLOCK, 1/2-13 ZN, G8
12	3034479	2	SCREW, M12-175 X 100MM
13	FWF050106010	18	WASHER, FLAT 1/2" SAE ZINC
14	FCS063011200	16	SCREW, HEX CAP 5/8-11 X 2 GR5 ZN
15	3006202	12	SCREW, HEX HD - 1/2-13 X 1-1/2 GR 8 ZC
16	3001176	16	NUT, SERRATED FLANGE 5/8-11 ZN
17	-	1	TRUCK FRAME
18	-	1	VEHICLE TOW HOOK
19	-	8	NUT, VEHICLE FASTENER

INSTRUCTIONS

1. Remove the bumper and bumper fasteners. Set aside for later reinstallation.
2. Remove the PS tow hooks by loosening 4 Nuts. Keep all fasteners for later re-installation.
3. Secure the PS SIDE PLATE (5) to the frame. Attach the tow-hook onto the sideplate like a sandwich and secure the four Nuts removed earlier. FIG 1.

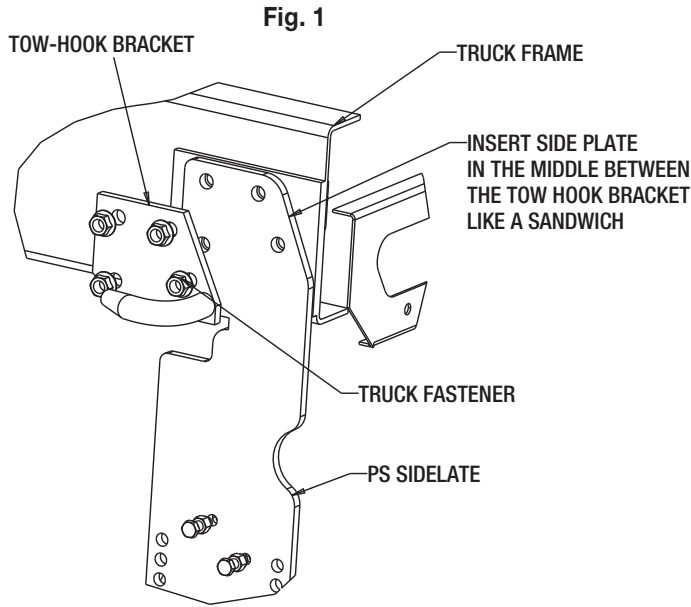

4. Repeat for the DS Side Plate (5).
5. Install the pushbar onto the two side plates using eight 5/8 bolts (14) and eight 5/8 nuts (16). Adjust the pushbar up and down. The center of the pushbar Cross Pin should be approximately 11 inches from the ground. (FIG 2)

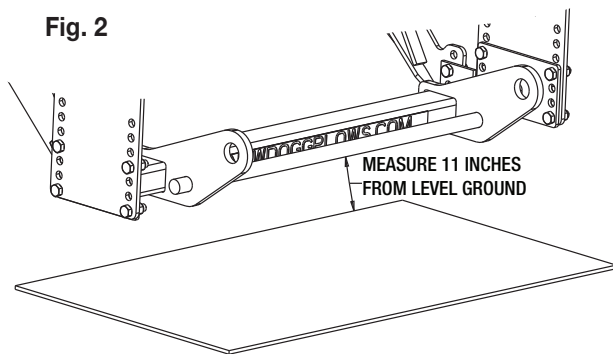

6. Hold the Rear Brace (4) onto the frame. Mark & drill two 5/8" holes. Secure it with the 5/8 fasteners provided (14,16). Drill 1 of 2 holes in the bottom for 1/2" fasteners (12,15). Attach the rear brace to the pushbar-bracket and secure it with two 1/2" fasteners (12,15). FIG 3

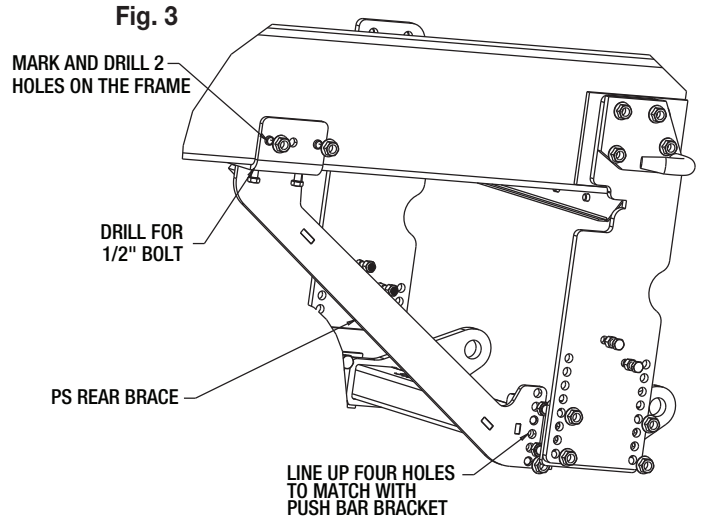

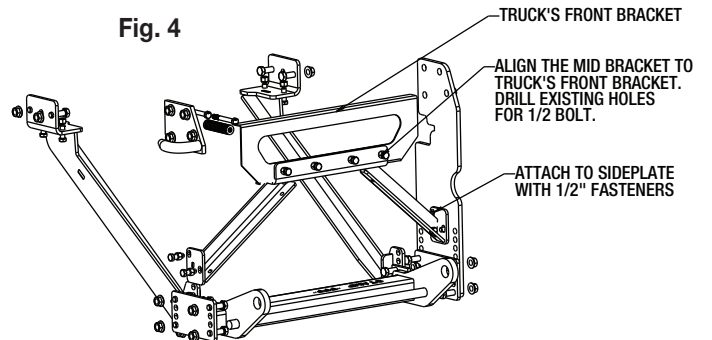

7. Repeat for the DS rear brace (3).
8. Install the Mid Brace Spacer (2) onto the frontal part of the truck. The angle will sit right onto the center location. Drill the four small holes for the 1/2" bolts. Secure the Mid brace Spacer to the Side Plates (5) with four 1/2" fasteners (12,15). FIG4

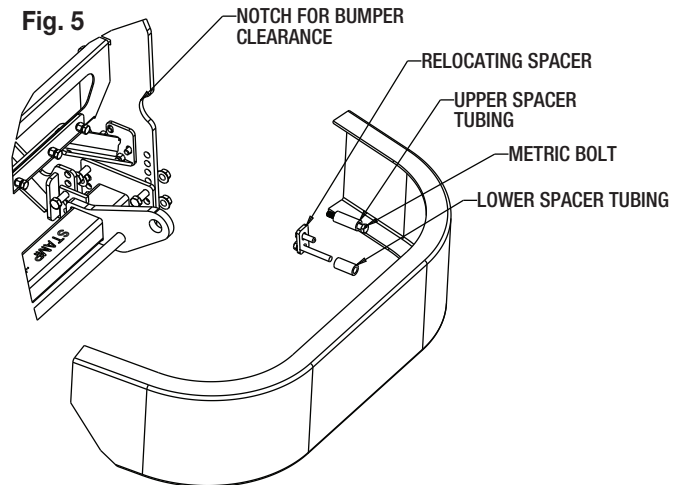

9. Reinstall the bumper back onto the truck with the spacer kit. Use the longer metric bolt (11) with the longer spacer tubing (8) on the upper hole of the bumper. Use the shorter tubing (7) for the lower hole. Install the relocating Spacer (6) and secure it with the 3.5" bolts (10). FIG. 5



10. Torque all fasteners as shown in the chart. Check and re-torque all fasteners after 5 hours of usage to ensure safe plow operation. Ensure all coolant lines and wires are clear from moving or hot components.

Recommended Fastener Torque Chart (ft.-lb.)			
Size	 SAE Grade 2	 SAE Grade 5	 SAE Grade 8
1/4-20	6	9	13
5/16-18	11	18	28
3/8-16	19	31	46
3/8-24	24	46	68
7/16-14	30	50	75
1/2-13	45	75	115
9/16-12	66	110	165
5/8-11	93	150	225
3/4-10	150	250	370
7/8-9	150	378	591
1-8	220	583	893

Metric Grade 8.8 (ft.-lb.)			
Size	Torque	Size	Torque
M6	7	M12	60
M8	17	M14	95
M10	35	M16	155

These torque values apply to fasteners except those noted in the instruction.

WARNING

- DO NOT under any circumstances disable, remove or relocate any sensors or components related to the operation of the air bags.
- Always follow the vehicle manufacturers' recommendations relating to snowplow installation.
- To comply with Federal Regulations and to assure a safe vehicle, the Front Gross Axle Weight Rating (FGAWR), Rear Gross Axle Weight Rating (RGAWR), and the Gross Vehicle Weight Rating (GAWR) must not be exceeded at any time.
- Due to the variety of equipment that can be installed on this vehicle, it is necessary to verify that the Front Gross Axle Weight Rating (FGAWR), Rear Gross Axle Weight Rating (RGAWR), and the Gross Vehicle Weight Rating (GAWR) are not exceeded at any time. This may require weighing the vehicle and adding ballast as necessary. It may also limit payload capacity of the vehicle. It is the operator's responsibility to verify that these ratings are not exceeded.

CAUTION

- Read all instructions prior to assembly
- It is critical that all fasteners be properly torqued for safe plow operation – see chart above.
- Fasteners should be retorqued after 5-8 hours of plow use

FULL ONE-YEAR WARRANTY

Manufacturer will repair, or at manufacturer's discretion will replace any part of this snowplow which proves to be defective in workmanship or material under normal use for a period of one year from the date of delivery to the original purchaser. Any cost incurred in returning the product to the supplier is the responsibility of the consumer.

EXCLUSIONS

Manufacturer shall not be liable for special, incidental, or consequential damages, or for damages resulting from lack of necessary maintenance, from misuse, abuse, acts of God, or alteration of the product. Some states do not allow the exclusion or limitation of incidental or consequential damages, so the above limitation or exclusion may not apply to you.