

# Installation Instructions

## TGS01B Salt Spreader

### Safety Precautions

#### **WARNING**

Observe the following Safety Precautions before, during and after operating this spreader. By following these precautions and common sense, possible injury to persons and potential damage to this machine may be avoided.

1. Read this entire Owners Manual before operating this spreader.
2. Read all safety decals on the spreader before operating.
3. Verify that all personnel are clear of the spreader spray area before starting or operating this spreader.
4. Do not adjust, clean, lubricate or unclog material jams without first turning off the spreader.
5. Make sure the spreader is securely fastened to the vehicle in accordance with this manual.
6. Do not operate a spreader that is in need of maintenance or repairs.
7. Always disconnect the battery before removing or replacing electrical components.

### Spreader Assembly

Check contents of box against parts list to make sure all components are included. When ordering replacement or spare parts refer to parts list (fig. 3) for part numbers.

### Installation (fig. 1)

1. Locate and mark center of tailgate.
2. Assembly Angles (24) and Braces (23) as shown in Fig.1 Use 3/8" carriage bolts, flat washers and nuts. Do not tighten fasteners at this moment.
3. Center assembly on top of tailgate. Lower angle must be flush with top and inside surfaces of tailgate.



#### **SPREADER WARRANTY INFORMATION**

This warranty replaces all previous warranties and no employee of this company is authorized to extend additional warranties, or agreements, or implications not explicitly covered herein.

Buyers Products Company warrants all parts of the product to be free from defects in material and workmanship for a period of one (1) year. Parts must be properly installed and used under normal conditions. Normal wear is excluded.

Any part, which has been altered, including modifications, misuse, accident, or lack of maintenance will not be considered under this warranty.

The sole responsibility of Buyers Products Company under this warranty is limited to repairing or replacing any part(s), which are returned, prepaid, 30 days after such defect is discovered, and returned part(s) are found to be defective by Buyers Products Company.

Authorization from Buyers Products Company must be obtained before returning any part. The following information must accompany defective parts returned to Buyers Products Company: RMA #, spreader model, serial number, date installed, and distributor from whom purchased.

Buyers Products Company shall not be liable for damage arising out of failure of any unit to operate properly, or failure, or delay in work, or for any consequential damages. No charges for transportation or labor performed on any part will be allowed under this warranty.

4. Position braces (23) on top of side rails. Using holes in braces as guides mark and drill holes for 3/8" screws.
5. Attach braces to side rails using 3/8" screws, flat washers and nuts.
6. Center spreader assembly on top of rear bumper and align with Angle (24).
7. Attach Mounting Angles (22) to spreader frame.
8. Make sure spreader frame is vertical. Using holes in Angle (24), mark and drill holes for 3/8" screws in Mounting Angle (22).
9. Using holes in spreader frame as guides, mark and drill holes for 3/8" screws in rear bumper.
10. Assemble spreader to Angles (24) and rear bumper. Adjust position of Angles (24) to bring spreader into vertical position. Tighten all screws at this moment.
11. Close tube with plastic caps provided.

**Torque Chart**

BOLT/NUT SIZE	TORQUE (ft.-lbs.)
1/4-20	6.0
5/16-18	11.0
3/8-16	20.0

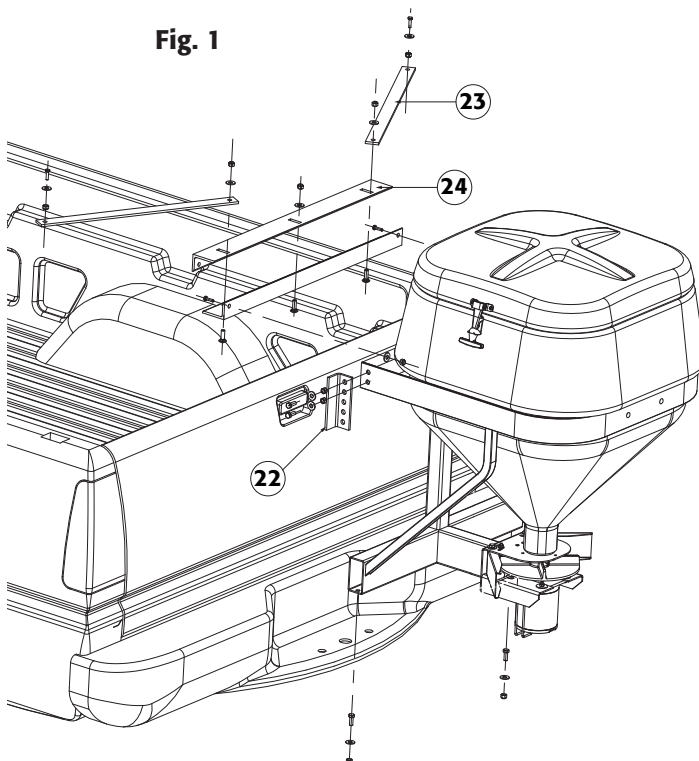

**Fig. 1**

**Electrical Installation** (fig. 2)

**⚠ WARNING**

**Do not drill holes into fuel tanks, fuel lines, through electrical wiring, etc that may be damaged by drilling. To insure good performance of your spreader, check the condition of truck's electrical system. Using digital voltmeter, check alternator and battery voltage. With engine running and head lights and heater fan ON good voltage reading should fall between 13.0 and 15.3 volts. If voltage reading falls out of this range, check and adjust your electric system.**

**NOTE: Always disconnect battery before attempting to install electrical components on your vehicle.**

- Mount the controller in a convenient location in the truck cab. It is recommended not to mount the controller directly in front of heat vents.
- Route both wire harnesses into truck cab through firewall (it maybe necessary to drill holes). Insulate hole to avoid water leaks.
- Insure no wires are nicked or damaged during installation.
- Connect the 4-pin connecter on the wire harness to the control box.
- Connect the 2-pin connector on the power cable to the control box.
- Connect fuse connector to the fuse terminal or ignition switch.
- Lay out a path for the power cable to the battery, use quick ties to secure power cable. **DO NOT CONNECT TO BATTERY AT THIS TIME!**
- Lay out path for wire harness to the rear of the vehicle. It is recommended to stay clear of the exhaust system. Excess heat can damage the wire harnesses. Use quick ties to secure harness to underbody.
- Connect the wire harness to the motor.
- Connect the power and ground cables directly to the battery.
- Insure all functions of the controller are working properly.

**Fig. 2**

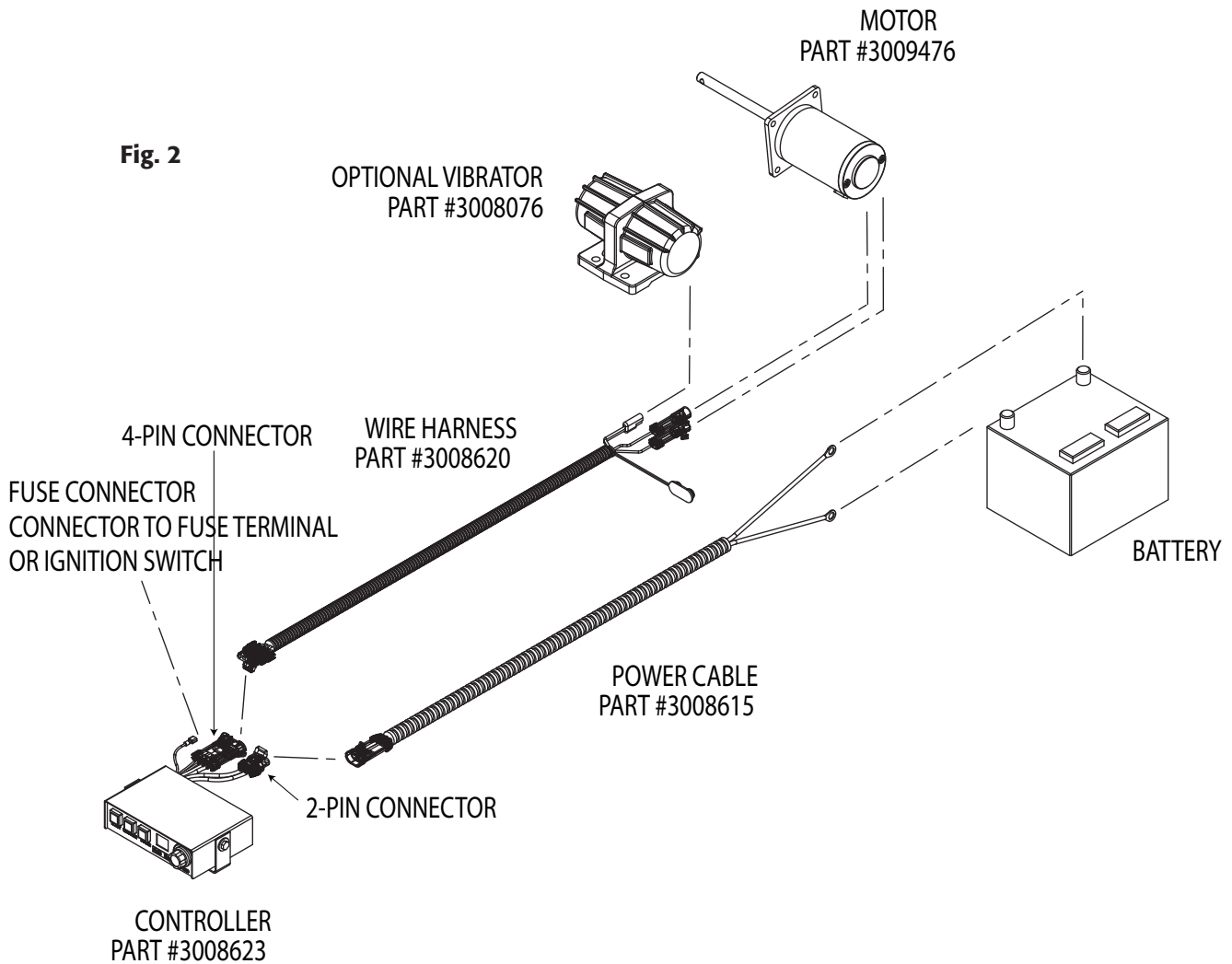

Observe spinner direction of rotation. The correct direction is counter clock wise when looking inside hopper from the top. If direction is clock wise reverse wires between Motor and Wire Harness.

### Spreader Maintenance

**1.** This spreader is designed to use loose free floating materials such as #1 dry Rock Salt. Using different grades and/or wet material will affect spreader performance. Wet material can “bridge” and stop floating onto spinner disk.

- 2.** Make sure lid is installed and latches are secured when spreader is in use.
- 3.** Do not leave material in hopper between uses.
- 4.** Do not drive with material in hopper.
- 5.** Always clean/wash hopper at the end of the day.
- 6.** Spray lubricant around motor shaft to prevent water from penetrating into the motor.
- 7.** Apply dielectric grease to all electrical connectors between uses and for long term storage.

#### **IMPORTANT**

**Make sure all wires securely attached to vehicle or spreader’s frame. Use wire ties and/or wire clamps to attach wires. All excess wires must be rolled into bangles and attached to vehicle or spreader.**

#### **CAUTION**

**Do not attempt to install or remove spreader with material in it.**

Fig. 3

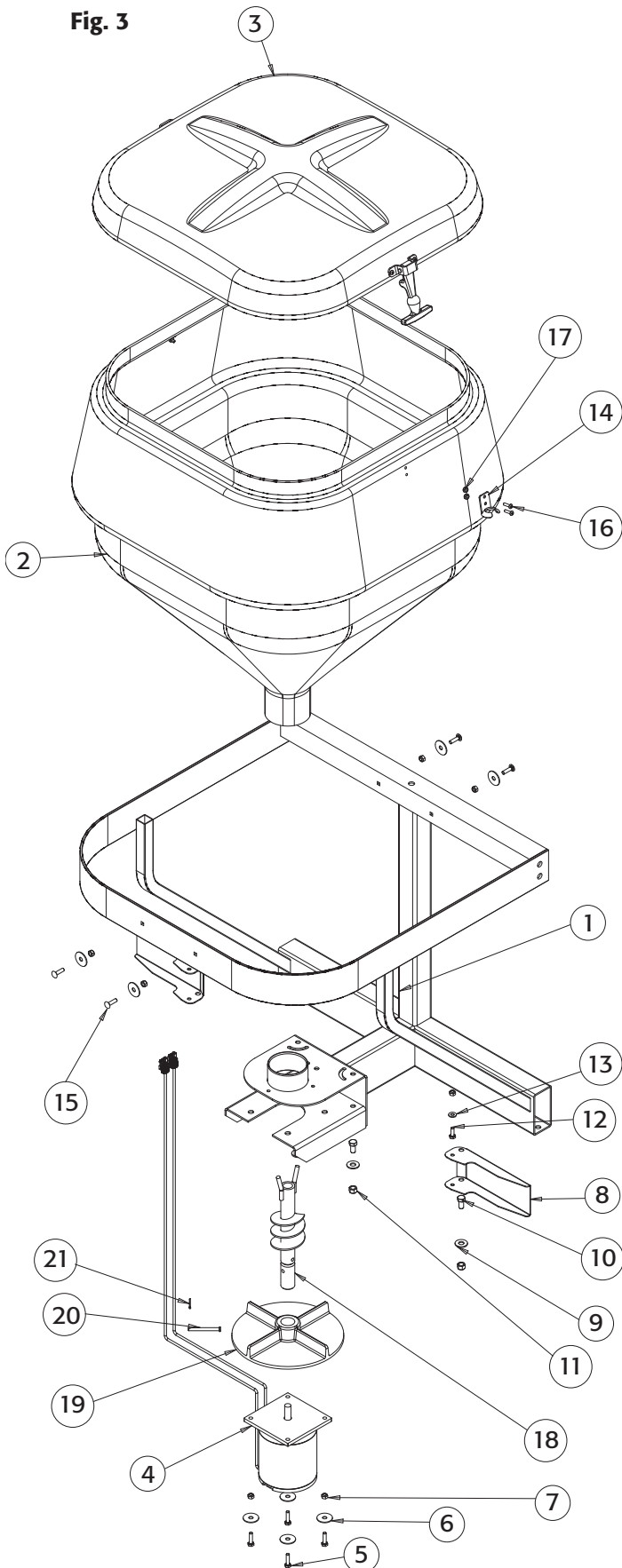

**Bill of Materials**

ITEM	PART NO.	QTY.	DESCRIPTION
1	3005920	1	Frame, Weldment, TGS01B
2	3013284	1	Hopper TGS01B
3	3003079	1	Lid, Assembly TGS01B
4	3009476	1	Motor 12 VDC, TGS
5	-	4	Screw, Cap Hex HD 1/4-20 x 1 SST
6	-	8	Washer, Fender 5/16" ID x 1-1/4" OD
7	-	10	Nut, Nylon Insert 1/4-20 SST
8	3005913	2	Shield, TGS01B
9	-	4	Washer, Flat 3/8 USS SST
10	-	4	Screw, HHC 3/8-16 x 3/4 SST
11	-	4	Nut, Nylock 3/8-16 x 7/16 SST
12	-	2	Screw, Cap 1/4-20 x 3/4 SST
13	-	2	Washer, Flat 1/4 SAE SST
14	3000626P	2	Keeper, Latch WJ201, Black
15	-	4	Bolt, Carriage, 1/4-20 x 1 SST
16	-	4	Screw, BHC #10-24 x .75 SST
17	-	4	Nut, Elastic Stop 10-24 SS
18	3007811	1	Auger w/ Set Srew TGS01
19	3005706	1	Spinner, Poly TGS01, TGS05, TGSUVPRO
20	-	1	Pin Clevis, 1/4 x 2.5
21	-	1	Cotter Pin, 5/64 x 3/4
22	3003617	2	Angle, Mounting Adapter, TGS01A/TGS01B
23	3003973	2	Mount Brace, TGS01A/TGS01B
24	3003620	2	Angle, Mounting, TGS01A/TGS01B